

# PRODUCT INFORMATION PACKET

Model No: 286TSTDN16036

Catalog No: E794A

30 HP General Purpose Motor, 3 phase, 1800 RPM, 230/460 V, 286TS Frame, ODP  
Three Phase ODP Motors



### Nameplate Specifications

Output HP	<b>30 Hp</b>	Output KW	<b>22.4 kW</b>
Frequency	<b>60 Hz</b>	Voltage	<b>230/460 V</b>
Current	<b>74.0/37.0 A</b>	Speed	<b>1775 rpm</b>
Service Factor	<b>1.15</b>	Phase	<b>3</b>
Efficiency	<b>94.1 %</b>	Power Factor	<b>81</b>
Duty	<b>Continuous</b>	Insulation Class	<b>F</b>
Design Code	<b>B</b>	KVA Code	<b>G</b>
Frame	<b>286TS</b>	Enclosure	<b>Drip Proof</b>
Thermal Protection	<b>No</b>	Ambient Temperature	<b>40 °C</b>
Drive End Bearing Size	<b>6311</b>	Opp Drive End Bearing Size	<b>6210</b>
UL	<b>Recognized</b>	CSA	<b>Y</b>
CE	<b>Y</b>	IP Code	<b>12</b>

### Technical Specifications

Electrical Type	<b>Squirrel Cage Inverter Rated</b>	Starting Method	<b>Line Or Inverter</b>
Poles	<b>4</b>	Rotation	<b>Reversible</b>
Resistance Main	<b>.22 Ohms</b>	Mounting	<b>Rigid base</b>
Motor Orientation	<b>Horizontal</b>	Drive End Bearing	<b>Ball</b>
Opp Drive End Bearing	<b>Ball</b>	Frame Material	<b>Cast Iron</b>
Shaft Type	<b>TS</b>	Overall Length	<b>25.44 in</b>
Frame Length	<b>15.12 in</b>	Shaft Diameter	<b>1.625 in</b>
Shaft Extension	<b>3.44 in</b>	Assembly/Box Mounting	<b>F1/F2 CAPABLE</b>
Connection Drawing	<b>A-EE7308K</b>	Outline Drawing	<b>B-SS207882-1512</b>

This is an uncontrolled document once printed or downloaded and is subject to change without notice. Date Created:10/06/2020

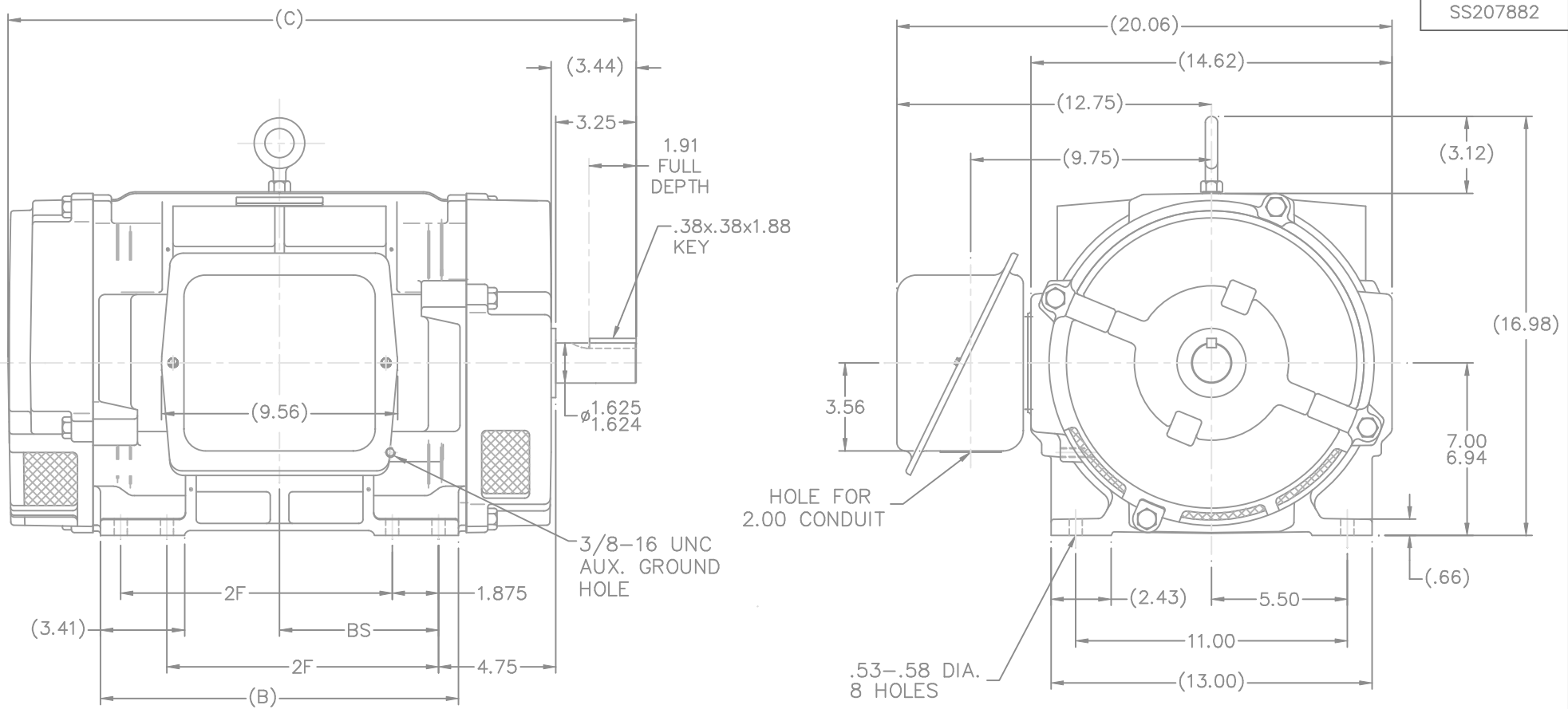

NOTES:

1. CONDUIT BOX CAN BE ROTATED IN 90. STEPS.
2. CONDUIT BOX CAN BE MOUNTED ON OPPOSITE SIDE BY REMOVING BRACKETS AND TURNING FRAME 180..
3. NAMEPLATE TO BE READ FROM CONDUIT BOX SIDE OF MOTOR.

DASH	FRAME	B	C	2F	BS
1325	284TS	12.63	23.57	9.50	5.50
1512	286TS	14.50	25.44	11.00	6.44

NO.		REVISION	BY & DATE	CHK	ANG	±7'30"	FINISH	PREV				
THIS DRAWING IN DESIGN AND DETAIL IS OUR PROPERTY AND MUST NOT BE USED EXCEPT IN CONNECTION WITH OUR WORK ALL RIGHTS OF DESIGN AND INVENTION ARE RESERVED THIS IS AN ELECTRONICALLY GENERATED DOCUMENT - DO NOT SCALE THIS PRINT				RFP	05-11-2004	CAD FILE	SS207882	SIZE	DRAWING NO.	PAGE	OF	REV.
				DIST	LB			B	SS207882			

TOLERANCES UNLESS SPECIFIED		MARATHON ELECTRIC		DRAWN	
DEC.	INCHES			TJB	05-04-2004
.X	±.1			CHK	ML 05-10-2004
.XX	±.03	TITLE		APPD	BW 05-11-2004
.XXX	±.005	OUTLINE		SCALE	1=4
.XXXX	±.0005	280 FR. - TS - DR.PR. - CAST IRON		REF	LI-03030025
		MAT'L		FMF	MU50708

LOW VOLTAGE



HIGH VOLTAGE



VIEW OF TERMINAL END

			TOLERANCES UNLESS SPECIFIED		 REGAL - BELOIT CORPORATION	DRAWN PGK 06-04-1997			
NO.	REVISION	BY & DATE	CHK	ANG		±	INCHES	SCALE	PREV
E	CORRECTED IEC MARKINGS ECD-0111208	WGJ 01-23-2017	EMH	DEC.				CHK ML 06-05-1997	
D	RE-DRAWN WITH REGAL LOGO ECD-0110493	WGJ 09-30-2016	EMH	.X	±.1			APPD GK 06-15-1997	
8	ADDED IEC DESIGNATIONS MU95020	TJW 4/30/2010	MJS	.XX	±.02		TITLE CONNECTION DIAGRAM		
7	REVISED HIGH VOLTAGE L2 WAS L3 CN52600-354	MRB 09-21-1998		.XXX	±.005		TITLE DELTA CON. - 3Ø - 9 LEADS	REF	
6	REDRAWN ON CADD	PGK 06-05-1997		.XXXX	±.0005		MAT'L.	FMF	
					±7'30"		FINISH		
THIS DRAWING IN DESIGN AND DETAIL IS OUR PROPERTY AND MUST NOT BE USED EXCEPT IN CONNECTION WITH OUR WORK ALL RIGHTS OF DESIGN AND INVENTION ARE RESERVED THIS IS AN ELECTRONICALLY GENERATED DOCUMENT - DO NOT SCALE THIS PRINT			RFP	CAD FILE EE7308K			SIZE A	DRAWING NO. EE7308K	PAGE OF REV. E
			DIST						

**CERTIFICATION DATA SHEET**

**Model#:** 286TSTDN16036 AA      **WINDING#:** K2864304 NONE 1  
**CONN. DIAGRAM:** A-EE7308K      **ASSEMBLY:** F1/F2 CAPABLE  
**OUTLINE:** B-SS207882-1512

**TYPICAL MOTOR PERFORMANCE DATA**

HP	KW	SYNC. RPM	F.L. RPM	FRAME	ENCLOSURE	KVA CODE	DESIGN
30&25	22.4&18.7	1800	1775&1475	286TS	DP	G	B

PH	Hz	VOLTS	FL AMPS	START TYPE	DUTY	INSL	S.F	AMB°C	ELEVATION
3	60/50	230/460#190/ 380	74/37&75/37.5	LINE OR INVERTER	CONTINUOU S	F3	1.15/1.15	40	3300

FULL LOAD EFF: 94.1&93	3/4 LOAD EFF: 94.1	1/2 LOAD EFF: 93.6	GTD. EFF	ELEC. TYPE	NO LOAD AMPS
FULL LOAD PF: 81&81.5	3/4 LOAD PF: 76.5	1/2 LOAD PF: 66	93.6	SQ CAGE INV RATED	31 / 15.5

F.L. TORQUE	LOCKED ROTOR AMPS	L.R. TORQUE	B.D. TORQUE	F.L. RISE°C
89 LB-FT	416 / 208	160 LB-FT 180	220 LB-FT 247	25

SOUND PRESSURE @ 3 FT.	SOUND POWER	ROTOR WK^2	MAX. WK^2	SAFE STALL TIME	STARTS /HOUR	APPROX. MOTOR WGT
72 dBA	82 dBA	4.7 LB-FT^2	- LB-FT^2	20 SEC.	-	460 LBS.

**\*\*\* SUPPLEMENTAL INFORMATION \*\*\***

DE BRACKET TYPE	ODE BRACKET TYPE	MOUNT TYPE	ORIENTATION	SEVERE DUTY	HAZARDOUS LOCATION	DRIP COVER	SCREENS	PAINT
STANDARD	STANDARD	RIGID	HORIZONTAL	FALSE	NONE	FALSE	NONE	BLUE (ENAMEL)

BEARINGS		GREASE	SHAFT TYPE	SPECIAL DE	SPECIAL ODE	SHAFT MATERIAL	FRAME MATERIAL
DE	OPE						
BALL	BALL	POLYREX EM	TS	NONE	NONE	1045 HOT ROLLED (C-204)	CAST IRON
6311	6210						

THERMO-PROTECTORS				THERMISTORS	CONTROL	SPACE /n HEATERS
THERMOSTATS	PROTECTORS	WDG RTDs	BRG RTDs			
NONE	NOT	NONE	NONE	NONE	FALSE	NONE VOLTS

If Inverter equals NONE, contact factory for further information

INVERTER TORQUE: CONSTANT 10:1
INV. HP SPEED RANGE: NONE
ENCODER: NONE
NONE NONE
NONE NONE PPR
BRAKE: NONE NONE
NONE P/N NONE
NONE NONE
NONE FT-LB NONE V NONE Hz

\*  
N  
O  
T  
E  
S  
\*

DATE: 06/27/2017 01:57:11 AM  
FORM 3531 REV.3 02/07/99

\*\* Subject to change without notice.

